

# Exalt® Banner Stand

Unique Curved, Retractable Design

exhibiting solutions



# Impact and Versatility

## Exalt® Banner Stand

Make an impact anywhere you need a big graphic in a small space. Exalt® is lightweight, convenient and flexible to fit your changing needs.

### Linear or Curved Design

With the simple flick of levers, Exalt converts from linear to curved. Connect three units together to create an effective inline display.

### Easy to Change Graphics

Exalt's Graphic Exchange System allows you to update or change your graphic to target specific audiences without investing in new hardware.

### Cases Protect Your Investment

Soft-sided carrying case and hard shipping case have handles and straps for easy transport. For inline displays, Exalt's Oval case holds three single units.

### Perfect For Many Settings

Exalt is great for trade shows, events, retail, lobbies and more.



Skyline produces its graphics in-house for the best quality and fit - guaranteed.

## Quick and Easy Graphic Exchange System!



Simply retract the existing graphic and slide it out of the base. Slide the new graphic into the base and raise the graphic.

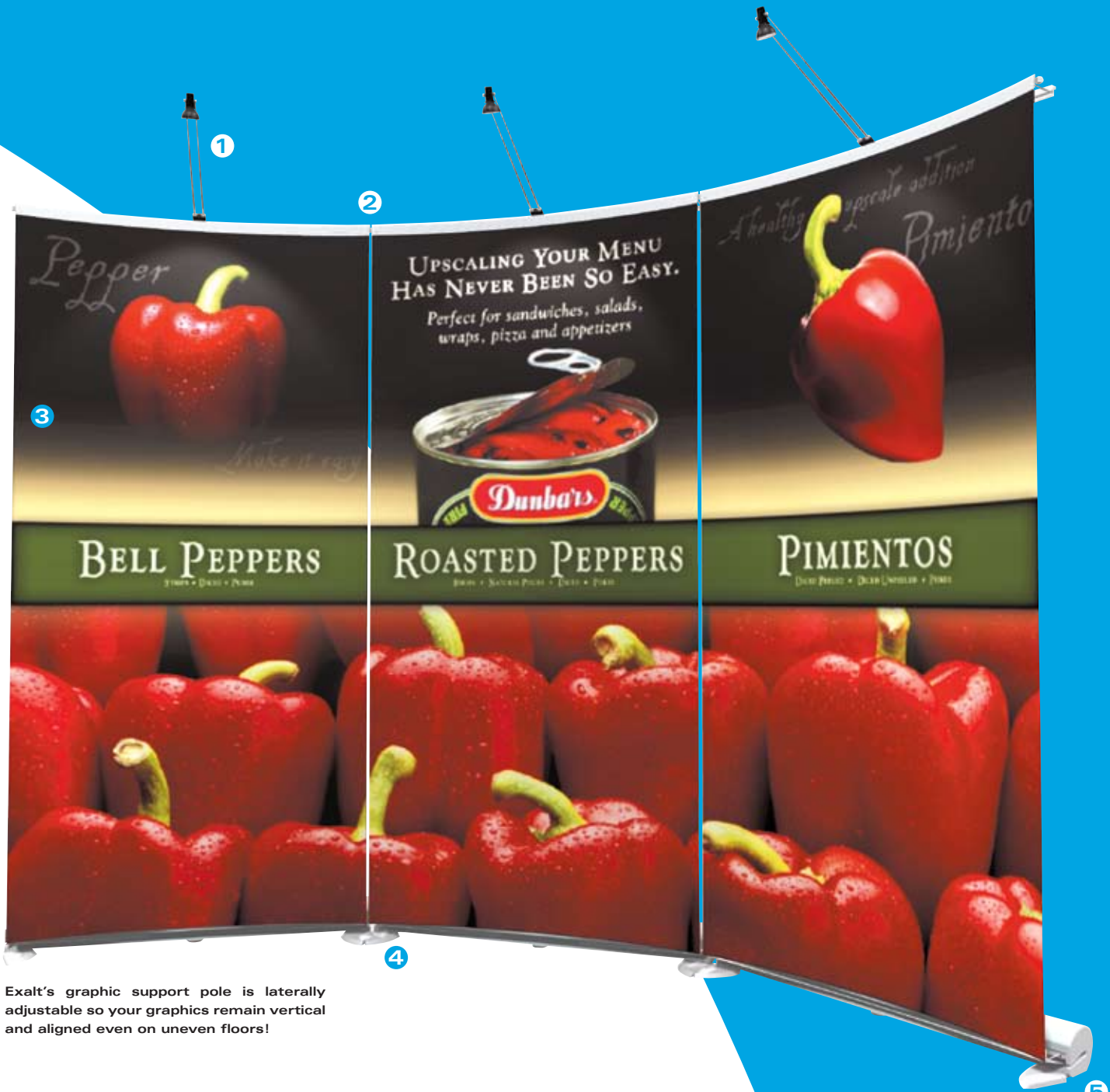

Exalt's graphic support pole is laterally adjustable so your graphics remain vertical and aligned even on uneven floors!

- 1 Halogen Lighting - 50 Watt**  
Attaches to the support pole and highlights your graphic.
- 2 Unit Connection System**  
Integral, low-profile magnets connect and align units for a precise brand presentation.
- 3 Fabric Graphic**  
Communicate your message in style with vibrant and durable Skyline fabric graphics.

- 4 Angled Support Feet**  
Support feet simply swivel open and are angled to match the curve of the graphic. Just align the feet to achieve the perfect curve.
- 5 Spring-Loaded Base**  
Protects graphic panel during transportation and storage. The base also contains a **Graphic Exchange System** which allows you to easily change your graphics on-site.

# Exalt® Banner Stand Specifications



Exalt can be designed for use as a full curved or linear banner stand that converts to a linear tabletop display.



Exalt's Oval case can be converted to an attractive case table with solid work surface and fabric graphics. Oval case fits 3 single Exalt units and table conversion kit.



Multiple units ensure brand consistency throughout your network of dealers and associates.

## 3-Unit Curved Backwall

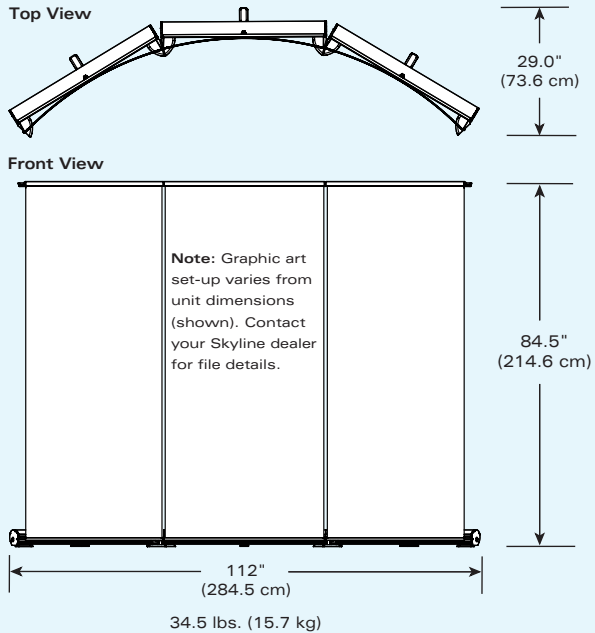

## 3-Unit Case

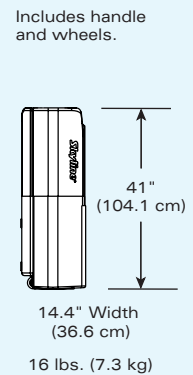

## Single Unit

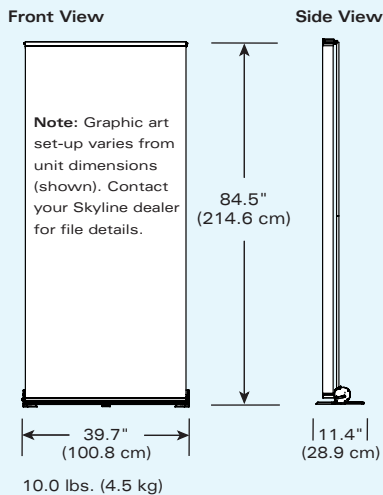

## Single Cases

Cases include shoulder strap and handles.

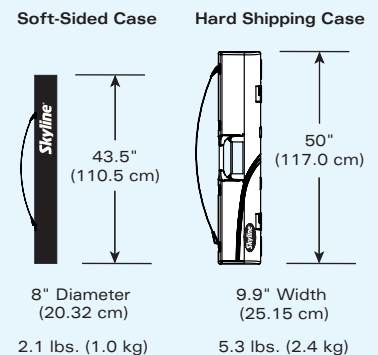

Patent #7,337,567

**Skyline Exhibits**  
3355 Discovery Road  
St. Paul, Minnesota 55121

1-800-328-2725  
1-651-234-6592 International

[www.skyline.com](http://www.skyline.com)

© 2008 Skyline Exhibits Printed in U.S.A.

PN31643-B